

Model-Based Estimation of Force and Displacement of a Hydraulic Cylinder

Keiwan Kashi, Dirk Söffker

Chair of Dynamics and Control, University Duisburg-Essen
Lotharstrasse 1, D-47057 Duisburg, Germany

Phone: +49-203-370-3429

Fax: +49-203-379-3027

E-mail: kashi@uni-duisburg.de, soeffker@uni-duisburg.de

Abstract

In recent years, hydraulic systems are gaining more and more grounds in applications of vehicle dynamics control and in particular active suspension systems. This is due to their small size-to-power ratio and the ability to apply very large forces and torques. In this contribution, a model-based technique is introduced to estimate the force and displacement of a hydraulic single-rod cylinder and therefore to eliminate the sensors or to achieve redundancy. The dynamics of single-rod cylinders are highly nonlinear due to the different piston areas and one of the more complex influences on a hydraulic cylinder is the friction force acting between the cylinder piston and the housing, which is not measurable. Another force acting on the cylinder is the external force, which is desired but usually not measured due to packaging and/or cost issues. The paper introduces the application of Proportional-Integral-Observer (PIO) approach to estimate the forces using a simple hydraulic model and only a few "easy-to-have" measurements. Experimental results from a hydraulic test-rig showing satisfying results are presented.

Topics / Vehicle Diagnostics, Monitoring, Data Acquisition and Processing

1. INTRODUCTION

In recent years, hydraulic systems are gaining more and more grounds in applications of vehicle dynamics control and in particular active suspension systems. This is due to their small size-to-power ratio and the ability to apply very large forces and torques.

The considered Active Suspension Control System (ASCS) developed by TRW Automotive Inc. is based on an electro-hydraulic system which is used

- to reduce the roll angle of the vehicle and improve the comfort in case of Active Roll Control (ARC),
- to change the dynamic behavior of the vehicle in order to improve its handling and comfort in case of Active Dynamic Control (ADC), or
- to combine the advantages of both systems with Active Dynamic Control II (ADC2) dependent on the arrangement of the actuators.

The system is actuated by hydraulic cylinders attached between the anti-roll bar and the chassis. The hydraulics is supplied by electro-hydraulic valves and pump, Nissing [1].

For the safety of the passengers and the avoidance of damages to the vehicle, the operation and performance of this system has to be monitored together with a fault detection strategy, both for the components as well as for the system. Lately, by using signal and/or model-based fault detection the number of sensors for this purpose has been minimized while at the same time an improved system monitoring and fault isolation have been realized, Isermann [2]. Another advantage of the model-based fault detection is that the system states which are difficult to measure can be monitored and used for fault detection and/or control purposes, Kashi [3].

2. SYSTEM MODEL

Modeling a hydraulic uniaxial drive system is described in numerous papers and books in the arrangement illustrated in Figure 1, Jelali [4]. The system consists of a translatory drive, a servo valve and a coupled mass.

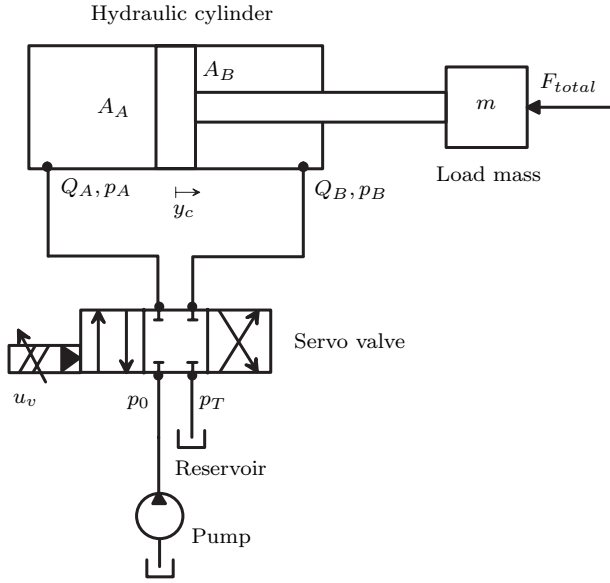

Figure 1. Hydraulic drive system configuration

The system inputs are the system pressure p_0 and the valve input voltage u_v . The output is the cylinder travel y_c . Other states of interest are both cylinder chamber pressures p_A and p_B .

In this contribution the interest is focused on the hydraulic cylinder, therefore the servo valve is neglected and the volume flow to each cylinder chamber are used as the inputs of the system. Hence the system under consideration has the inputs Q_A and Q_B , which can be calculated forward using system pressure p_0 , cylinder pressures p_A , p_B and valve input voltage u_v . The cylinder pressures are assumed to be available by measurement. The hydraulic cylinder is described as a state-space form with the state vector

$$\dot{x}(t) = \begin{bmatrix} \dot{y}_c(t) \\ p_A(t) \\ p_B(t) \end{bmatrix} \quad (1)$$

and the input vector

$$u(t) = \begin{bmatrix} Q_A(t) \\ Q_B(t) \end{bmatrix}. \quad (2)$$

The choice of the output vector depends on the available or desired measurements, which in this case are the chamber pressures, hence

$$y(t) = \begin{bmatrix} p_A(t) \\ p_B(t) \end{bmatrix}. \quad (3)$$

The state space model of the hydraulic cylinder can be written as, Spielmann [5],

$$\dot{x}(t) = \begin{bmatrix} \frac{1}{m(y_c)}(x_2 A_A - x_3 A_B - F_{total}) \\ \frac{E_{oil}(x_2)}{V_A(y_c)}(u_1 - x_1 A_A) \\ \frac{E_{oil}(x_3)}{V_B(y_c)}(u_2 + x_1 A_B) \end{bmatrix}. \quad (4)$$

Here, the moving mass m is considered as the sum of the coupled mass and the moving oil masses in the cylinder chambers which in their turn are dependent on the cylinder piston travel $y_c(t)$. The oil bulk modulus of cylinder chambers $E_{oil}(x_i(t))$ are logarithmic functions depending on the chamber pressures $p_A(t)$ and $p_B(t)$, Murrenhoff [6]. The friction and the external forces are added to represent the total force acting on the cylinder piston denoted as F_{total} . Leakages between the cylinder chambers as well as external oil leakages are neglected in this consideration, since their influence on the cylinder dynamics are minimal.

The equation of motion for the valve spool is described by a second order differential equation and the nonlinear equation describing the turbulent oil volume flow of the valve is given in Spielmann [5]. The valves unsymmetrical behavior is also considered here. The structure of the system is illustrated in Figure 2.

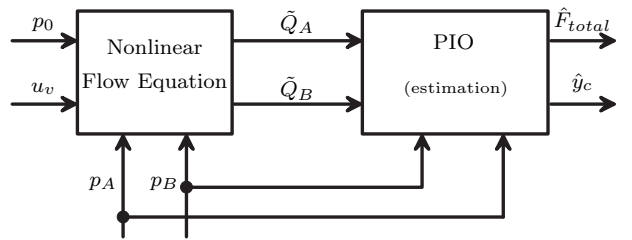

Figure 2. Structure of input calculation for the PIO

2.1 Simplified Model

For the model-based description used for PI-observer design the nonlinearities described in the previous chapter are neglected, hence the model is simplified for the linear observer design. The

design idea of this observer is to make the observer robust with respect to unknown inputs (which are also estimated) and modeling errors.

Assuming that the moving mass m , the oil bulk modulus E_{oil} are constants and that both chamber volumes V_A and V_B are constants and equal, the state space equation simplifies to

$$\dot{x} = \begin{bmatrix} 0 & \frac{A_A}{m} & -\frac{\alpha A_A}{m} \\ -\frac{A_A E_{oil}}{V} & 0 & 0 \\ \frac{\alpha A_A E_{oil}}{V} & 0 & 0 \end{bmatrix} x + \begin{bmatrix} 0 \\ \frac{E_{oil}}{V} Q_A(p_A, p_B, u_v) \\ \frac{E_{oil}}{V} Q_B(p_A, p_B, u_v) \end{bmatrix} + \begin{bmatrix} F_{tot} \\ m \\ 0 \\ 0 \end{bmatrix}, \quad (5)$$

$$y(t) = \begin{bmatrix} p_A(t) \\ p_B(t) \end{bmatrix}.$$

The nonlinear equation for the turbulent oil volume flow contains switching function which are approximated as arctan-functions, Kashi [7].

3. OBSERVER

Regarding the forces acting on the cylinder piston as external unknown inputs and by using the knowledge (based on the linearized model) of the cylinder dynamics, the forces are estimated using the PIO. So by using the PIO, neither a model of the disturbances nor a detailed complex nonlinear model of the system dynamics are required. This is optimal for applications where no model is available like the exact dynamic behavior of the external forces acting on the cylinder or the model is too complex or not so perfect as assumed, like for friction forces in the cylinder.

The effect of unknown external disturbances is considered within the state space representation

$$\dot{x} = Ax + Bu + Nn(x, u, t), \quad y = Cx, \quad (6)$$

with the state vector x of order n , the measurements vector y of order r_1 and the input vector u of order m . The system matrix A , the input matrix B and the output matrix C are of appropriate dimensions. The vector $n(x, u, t)$ of order r_2 describes the external unknown inputs, in this case the external cylinder force. For the application of the PIO the number of independent measurements r_1 has to be equal or higher than the number of considered external inputs r_2 , Söffker [8]. Another

assumption for the application of the PIO is, that the whole (extended) system is observable. The matrix N locates the external effects to the system description and is assumed as to be known. The structure of the classical PIO is given in Figure 3.

In addition to the conventional Luenberger ob-

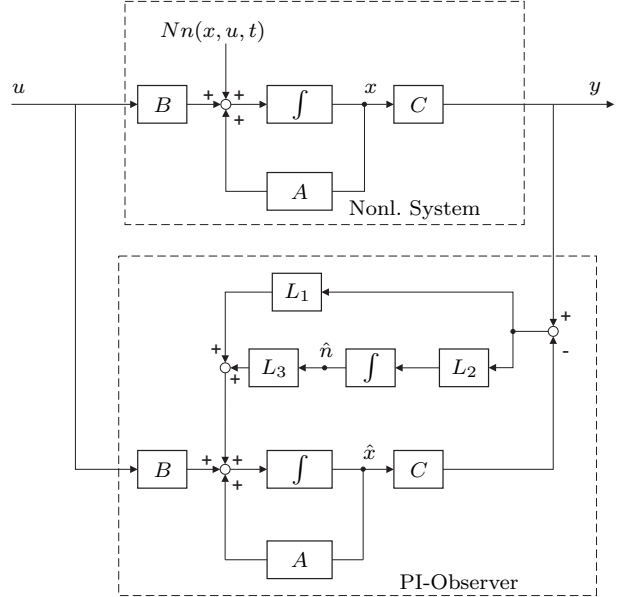

Figure 3. Structure of classical Proportional-Integral-Observer PIO

server an integral of the estimation error is used in a second loop. The dynamics of the PIO is described by

$$\dot{\hat{x}} = A\hat{x} + L_3\hat{n} + Bu + L_1(y - \hat{y}), \quad \hat{y} = C\hat{x}, \quad (7)$$

$$\dot{\hat{n}} = L_2(y - \hat{y}). \quad (8)$$

The matrix L_3 locates the disturbance and is a linear scaling of the matrix N . In Söffker [9], the details for high and suitably chosen observer gains L_1 , L_2 and L_3 , scaled in an appointed ratio and their effect on the estimation of the observer state vector \hat{x} and the estimation of the integral feedback \hat{n} is given. So the behavior becomes

$$(x - \hat{x}) \rightarrow 0 \quad \text{and} \quad (n - \hat{n}) \rightarrow 0. \quad (9)$$

In Söffker [9], it is shown that systems with nonlinearities can be handled as linear systems with additional unknown external inputs representing the nonlinearities.

With the estimation error $e = \hat{x} - x$, the error dynamics have the expression

$$\begin{bmatrix} \dot{e} \\ \dot{\hat{n}} \end{bmatrix} = \begin{bmatrix} A - L_1C & L_3 \\ -L_2C & 0 \end{bmatrix} \begin{bmatrix} e \\ \hat{n} - n \end{bmatrix}. \quad (10)$$

The observer gains are chosen such that the error dynamics as well as the observer itself is stable, Söffker [8].

4. EXPERIMENTAL RESULTS

Using a hydraulic test-rig as an example, the experimental results in Figure 4 illustrate a very exact estimation of the hydraulic cylinder velocity and displacement. The velocity of the piston y_c is estimated by the observer and by a second integrator the displacement y_c is calculated. The results show a good overall behavior of the force estimation as well.

Figure 5 illustrates a zoom of the result while the cylinders moves inwards to impact. As seen from the velocity and displacement measurements, the velocity of the piston decreases as the piston moves inwards to reach its saturation point. This is due to the fact that the cylinder of the test-rig has an impact damping mechanism. This behavior is not considered in the investigation, hence the estimation deviation.

Also the deviation in the force estimation can be explained by the same reason. The impact damping mechanism decrease the acceleration and velocity of piston which is not realized by the used model.

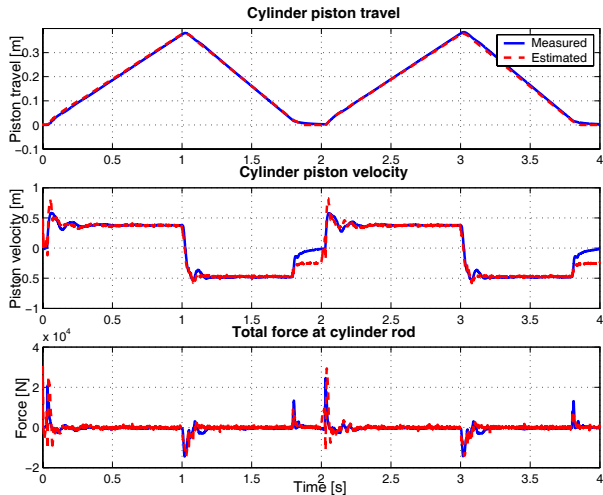

Figure 4. Measured and estimated force and displacement of the hydraulic cylinder

5. CONCLUSION

In this contribution a model-based technique is introduced to estimate the force and displacement of a hydraulic cylinder, based on a simplified hydraulic model. By only using the measurements

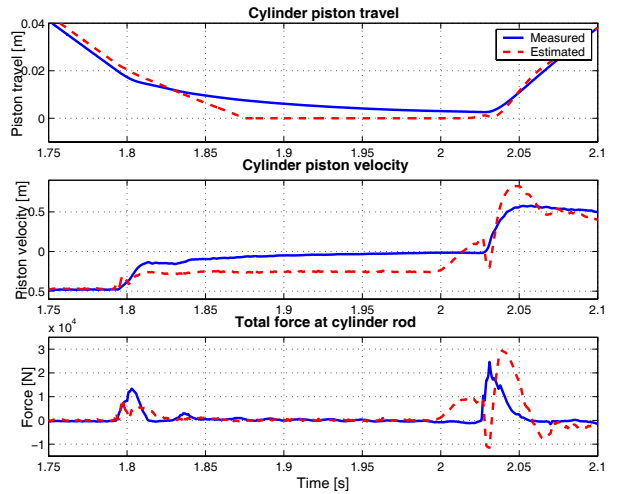

Figure 5. Zoomed: Measured and estimated force and displacement of the hydraulic cylinder

of the system and chamber pressures, the PI-observer estimates the force and displacement of the cylinder with a good and satisfying behavior. This makes it possible to replace force and displacement transducers with pressure transducers, hence gaining advantages in packaging and installation because of the difficulty to install sensors on moving parts such as cylinder pistons. This will also lead to cost saving since the force and displacement transducers cost relatively more than pressure transducers. The estimated force and displacements can also be used to ensure redundancy for the existing transducers and/or for fault detection approaches. This model-based technique will be used on a hydraulic Hardware-in-the-Loop test-rig Kashi [3] in order to estimate the nonmeasurable states of the Active Suspension Control System developed by TRW Automotive Inc. The proposed PIO concept can also be applied to other hydraulic or mechanical components like the valve-spool displacement or forces acting on the valve-spool. Further work is to optimize the model to take the impact forces into consideration hence achieving a much more exact force estimation. Further work could also be to estimate the forces without any knowledge about the inputs of the system, in this case the volume flows.

ACKNOWLEDGEMENTS

The authors would like to thank the TRW Automotive Inc. Düsseldorf, Active Suspension Team, Drs. Kesselgruber and Nissing for their fruitful discussions and support.

REFERENCES

- [1]. Nissing, D., Kesselgruber D.: "Erprobung von realen aktiven Fahrwerkregelsystemen im virtuellen Fahrzeug", Simulation und Simulatoren - Mobilität virtuell gestalten, VDI-Berichte 1745. Düsseldorf: VDI. 281-301. (2003).
- [2]. Isermann, R.: "Überwachung und Fehlerdiagnose: Moderne Methoden und ihre Anwendungen bei technischen Systemen", VDI-Verlag, Düsseldorf, Germany (1994).
- [3]. Kashi, K., Söffker, D., Nissing, D., Kesselgruber, D.: "Vehicle Dynamics Investigation Using a Hydraulic Hardware-in-the-Loop Test Rig", Conference Proceedings for the 1st International Conference on Computational Method in Fluid power Technology, Fluid Power Net Publications, ISBN 0-9578574-1-1, Melbourne, Australia (2003).
- [4]. Jelali, M., Kroll, A.: "Hydraulic Servo-systems: Modelling, Identification and Control", Springer Verlag, ISBN 1852336927, London (2003).
- [5]. Spielmann, M.: "Zustandsmodelle hydraulischer Antriebselemente", Research report No. 15/96, Gerhard-Mercator-University, Duisburg, Germany (1996).
- [6]. Murrenhoff, H.: "Grundlagen der Fluidtechnik - Teil 1: Hydraulik", Verlag Mainz, Wissenschaftsverlag, ISBN 3-89653-259-6, Aachen (1998).
- [7]. Kashi, K., Söffker, D.: "Model based estimation of internal and external forces on a hydraulic cylinder", Conference Proceedings for the 1st International Conference on Computational Method in Fluid power Technology, Fluid Power Net Publications, ISBN 0-9578574-1-1, Melbourne, Australia (2003).
- [8]. Söffker, D.: "Observer-based measurement of contact forces of the nonlinear rail-wheel contact areas as base for advanced traction control", 3rd International Heinz Nixdorf Symposium, Wallaschek, J., Lückel, J., Littmann, W. (eds.), Mechatronics and Advanced Motion Control, HNI-Verlagsschriftenreihe Vol. 49, 305-320 (1999).
- [9]. Söffker, D., Yu, Tie-Jun, Müller, P.C.: "State Estimation of Dynamical Systems with Nonlinearities by using Proportional-Integral Observer", International Journal of Systems Science, Vol. 26, No. 9, 1571-1582 (1995).