

BACHELOR THESIS

UNIVERSITÄT
DUISBURG
ESSEN



Electrical and Electronic Engineering

Measurement of Microwave In-Room Transfer Function (Antenna-Antenna)

Submitted by
Abdullah Demir
2231124

Supervised by
Prof. Dr.-Ing. K. Solbach
University of Duisburg-Essen
Department of Microwave and RF Technology

OUTLINE

1- THESIS TASK

2- HISTORY

3- BRIEFING

4- MEASUREMENT

5- CONCLUSION



Channel Transfer Function Measurement with usage of S-Parameter

Investigation of Statistical relations

Phase & Amplitude vs. Position & Frequency

Oldest Far-Field Communication System

- Smoke Signals - Wireless Communication

First groundbreaking work

- “Possibility of error-free transmission by using optimum power in frequency selective channels”, by *Claude Shannon* in 1948

Cellular Communication

- Started in 1970s and formulated within those years as well

Ultra-Wideband Systems (UWB)

- Spectrum Assignment till 2000
- In 2000 leakage of free spectrums
- UWB works within assigned spectrums but no interference

Vector Network Analyzer

- Ability of measuring S-Parameters
- Very good Calibration



METRICTEST.COM

Omni-Directional Antennas

- Receiver and Transmitter
- Used for point-to-multipoint network
- Increase of power/receiving sensitivity in one plane

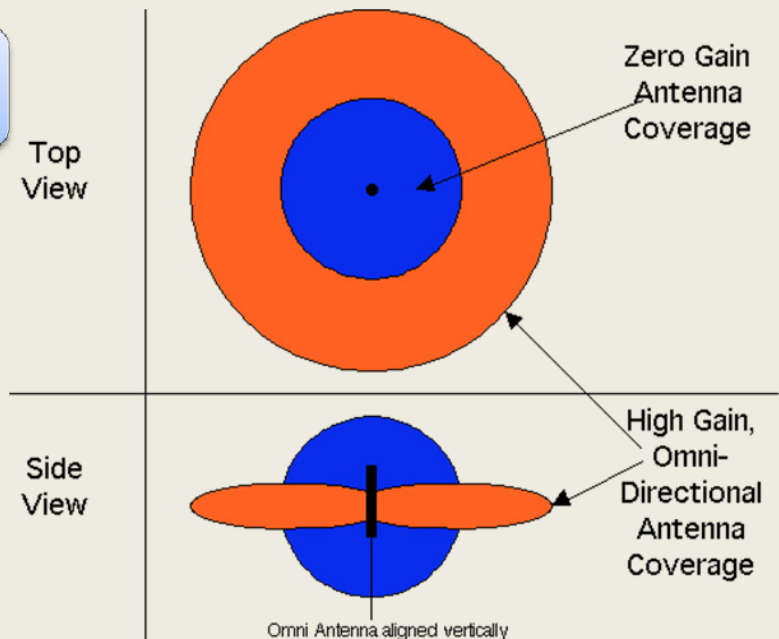



Line Of Sight (LOS) / Non-Line Of Sight (NLOS)

LOS: Direct Path

- Transmitter and receiver antenna in eye contact
- No Object in between
- Reflection

NLOS: No Direct Path

- Transmitter and receiver antenna in eye contact
- Objects between transmitter and receiver
- Reflection, Refraction and Defraction

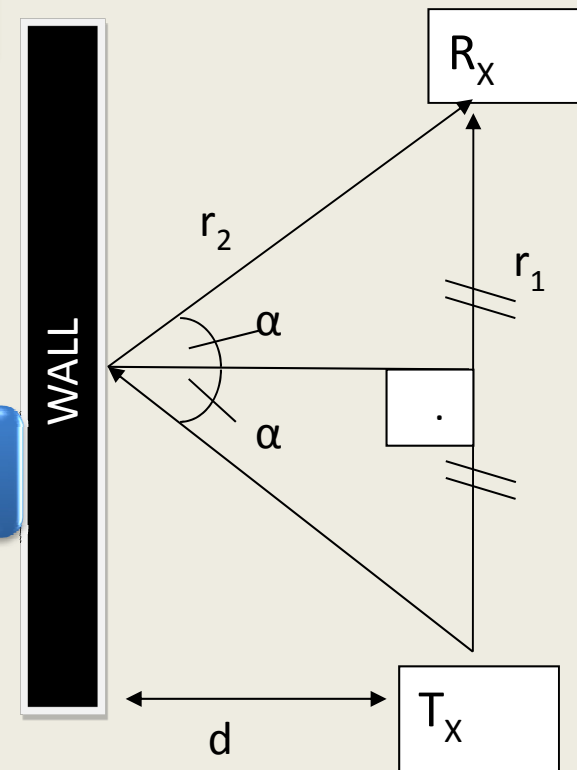

Scattering Parameters

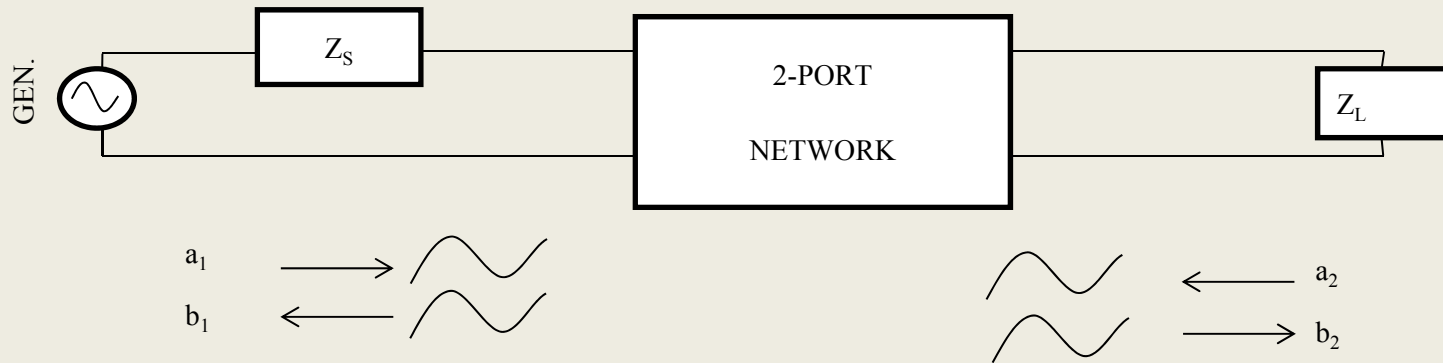

- Description of scattering Incident, Reflected and Transmitted Waves
- Determined by measuring the magnitude and phase
- S_{21} Forward transmission through network $S_{21} = \frac{b_2}{a_1} |_{a_2=0}$
- S_{21} used as Channel Transfer Function



Correlation

“Degree and type of relationship between any two or more quantities/variables in which they vary together over a period.”

$$\zeta = S_{21}^{(1)}(f) * S_{21}^{(2)}(f)$$

Or

$$\zeta = \int_{-\infty}^{+\infty} S_{21}^{(1)}(f) S_{21}^{(2)*}(f + \Delta f)$$

EQUIPMENT

1- Vector Network Analyzer

2- Omnidirectional Antenna(2X)

3- Coaxial cable

4- PC

5- Advanced Design Systems (ADS) 2009 Update 1 (Software)

6- MATLAB 2011a (Software)

PLACEMENT OF ANTENNAS

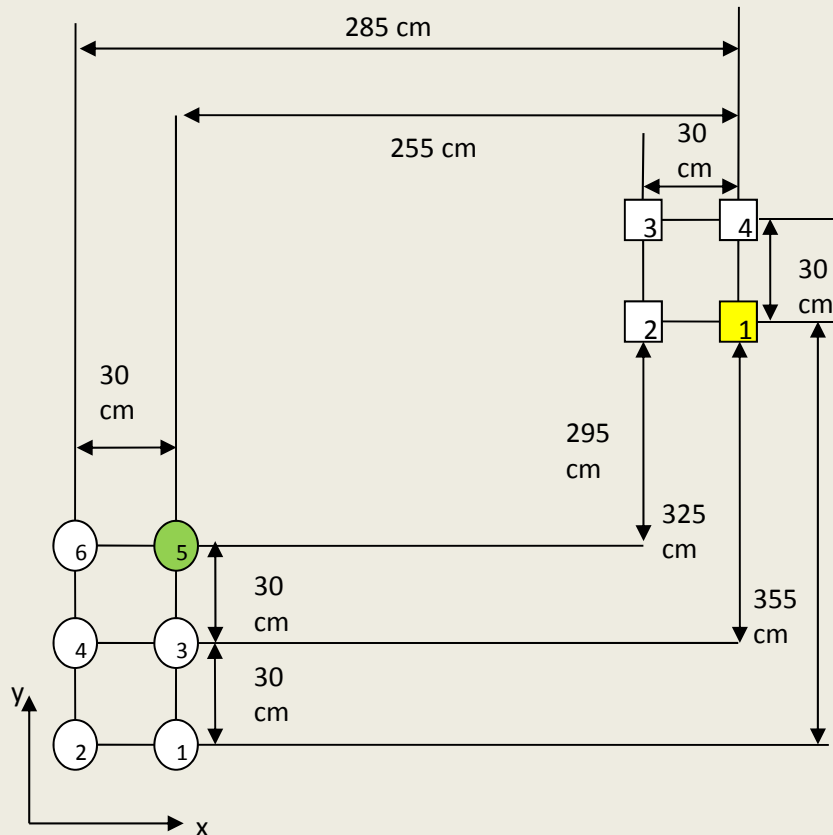

Receiver position 1



Transmitter position 5



STEP 1

- Measuring the S-Parameter and plotting in MATLAB

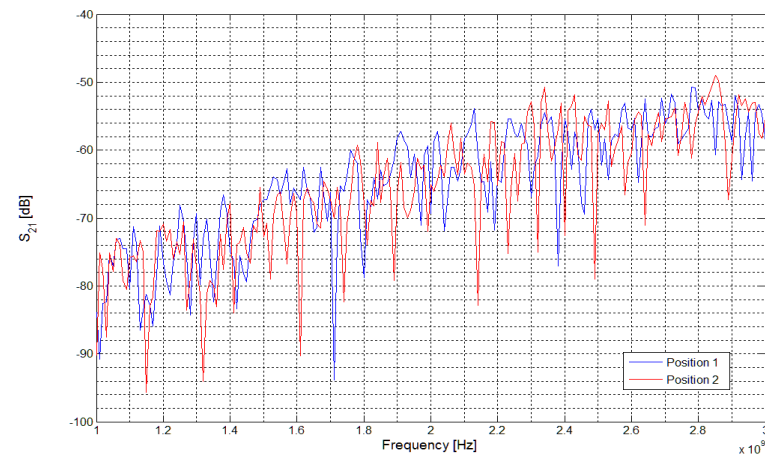
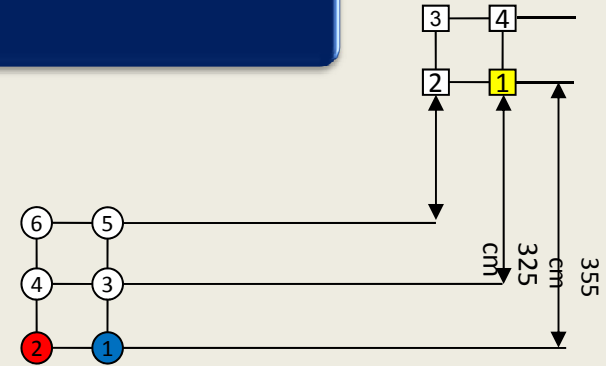
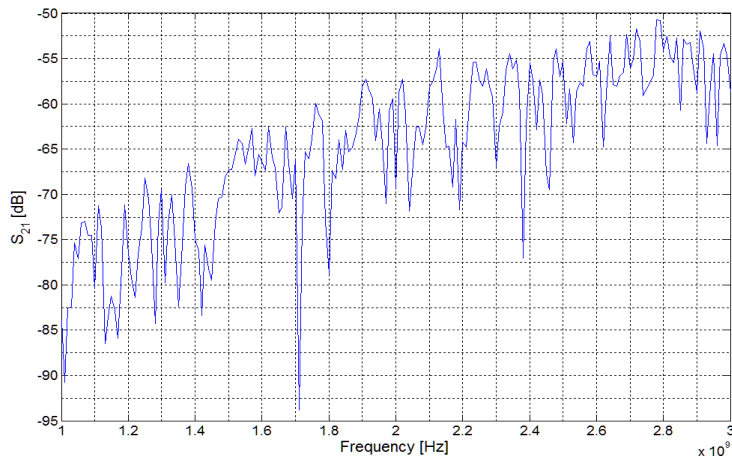



STEP 2

Auto-Correlation

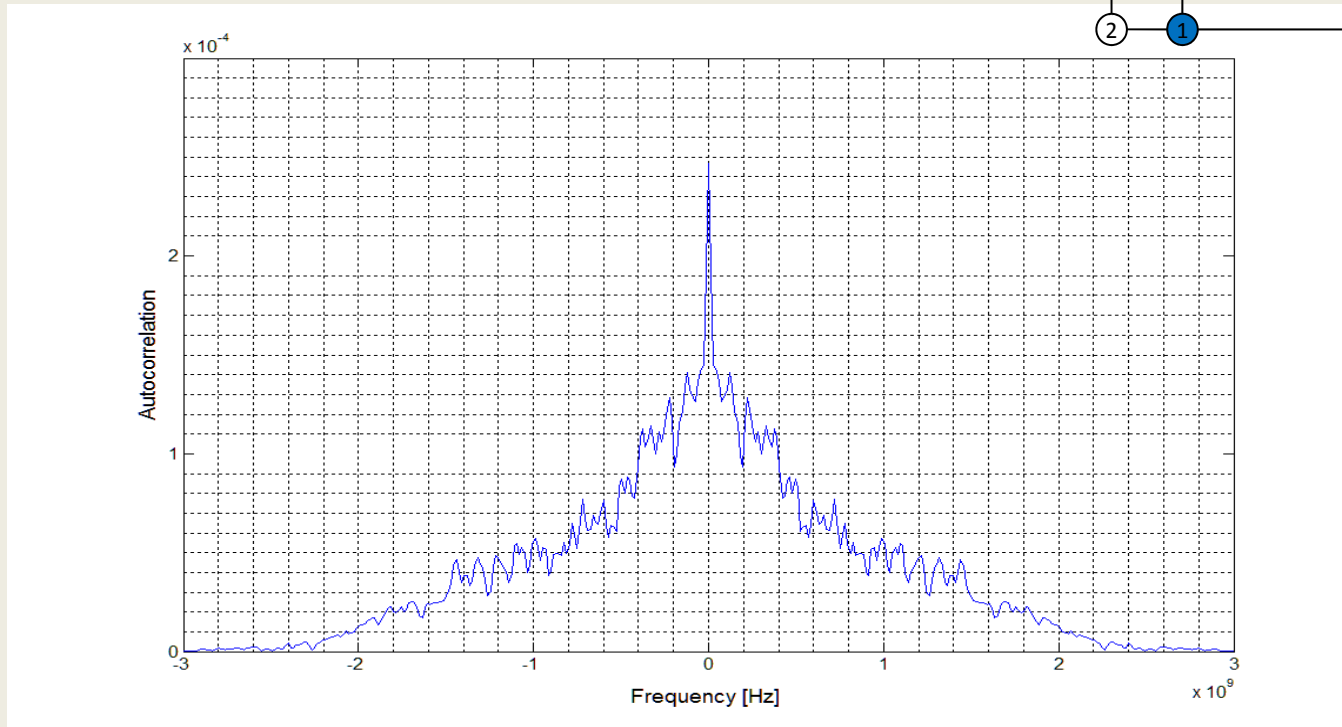
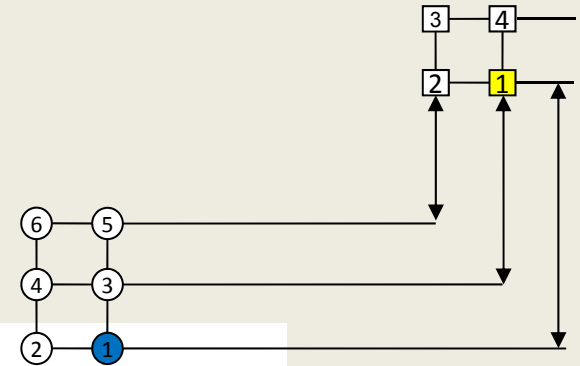



STEP 3

Cross-Correlation

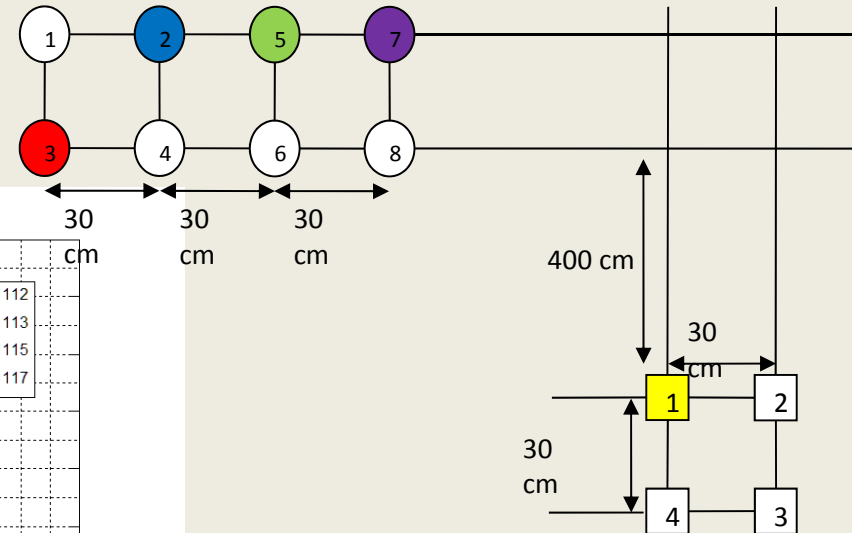
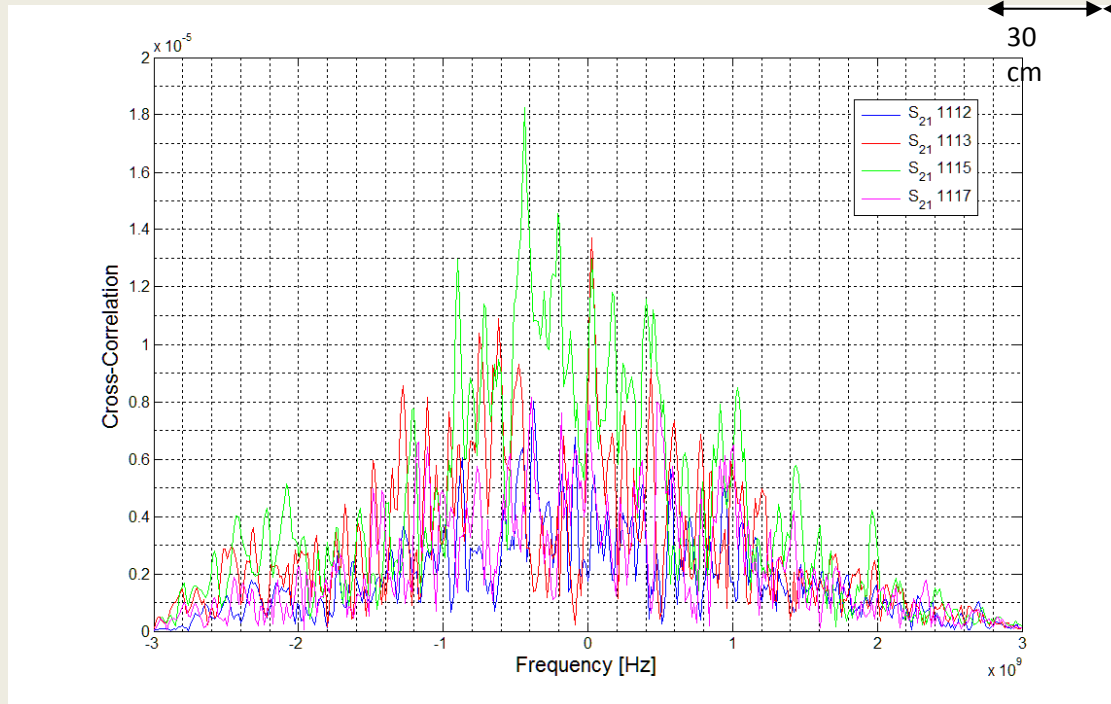

S₂₁ XY*XY
X=Receiver Position
Y=Transmitter Pos.



STEP 2

Auto-Correlation

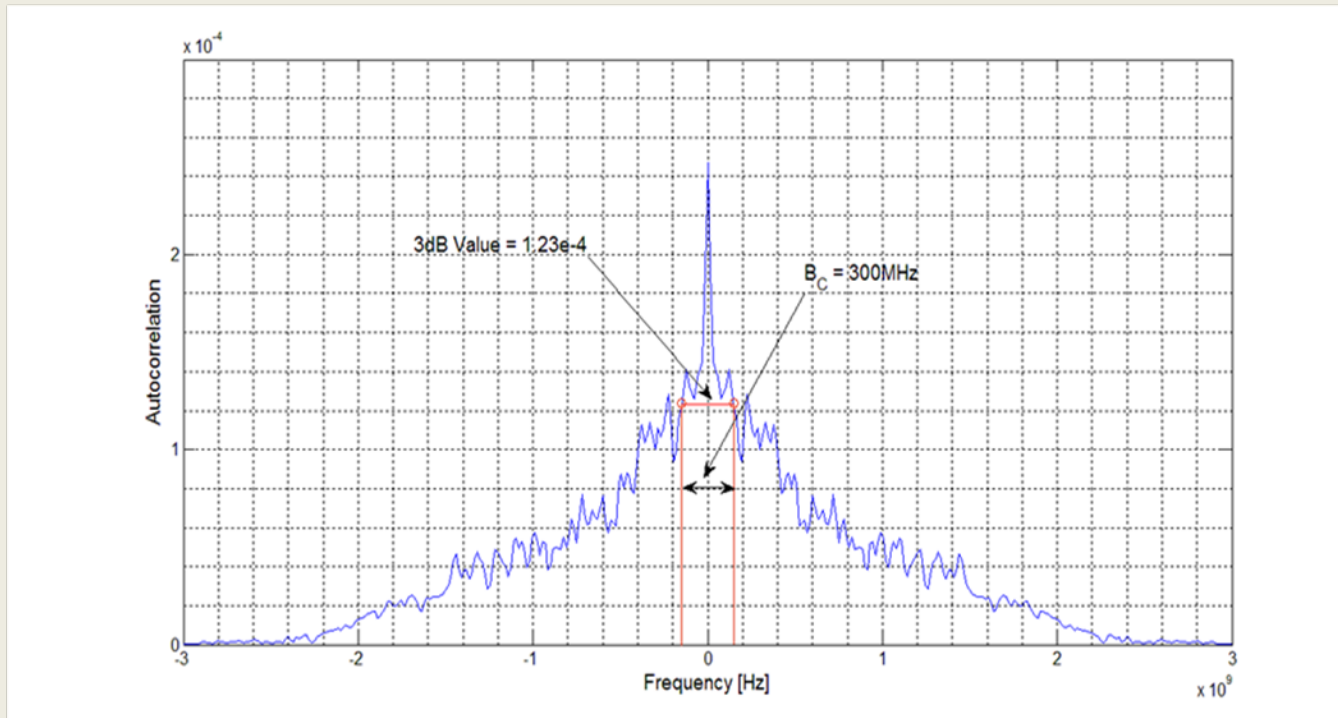



STEP 2

Auto-Correlation

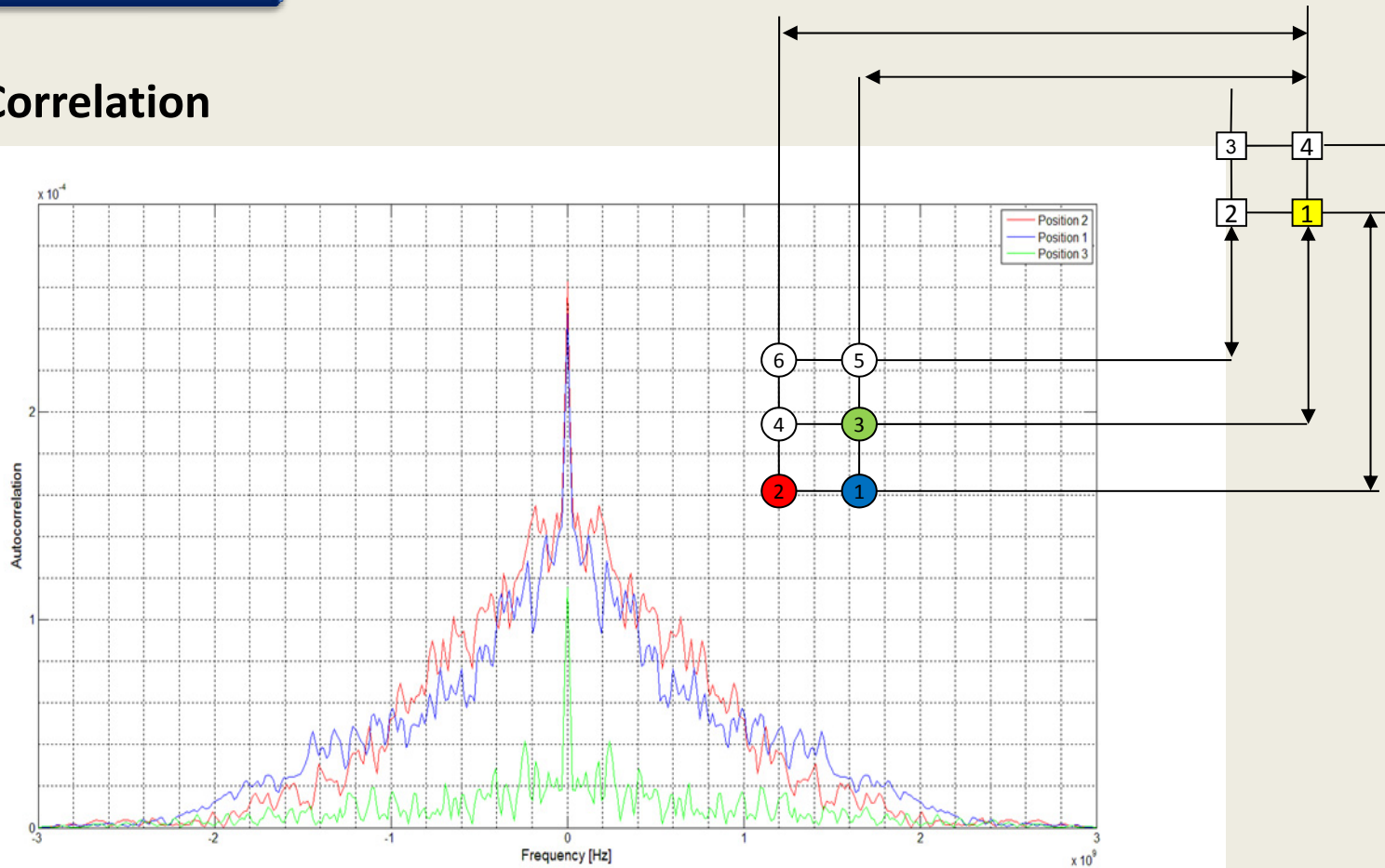

CONCLUSION



STEP 4

Comparison Auto-Correlation

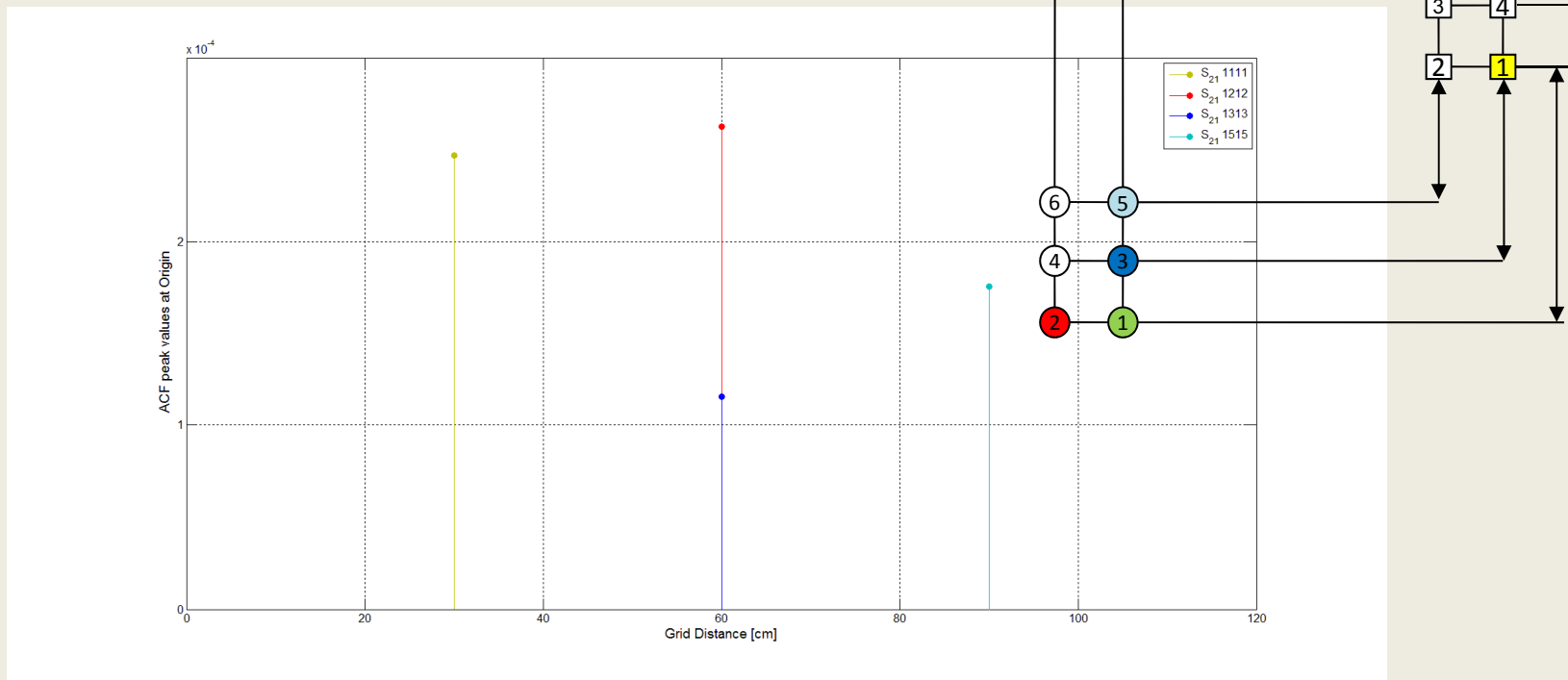

CONCLUSION



STEP 5

Cross-Correlation

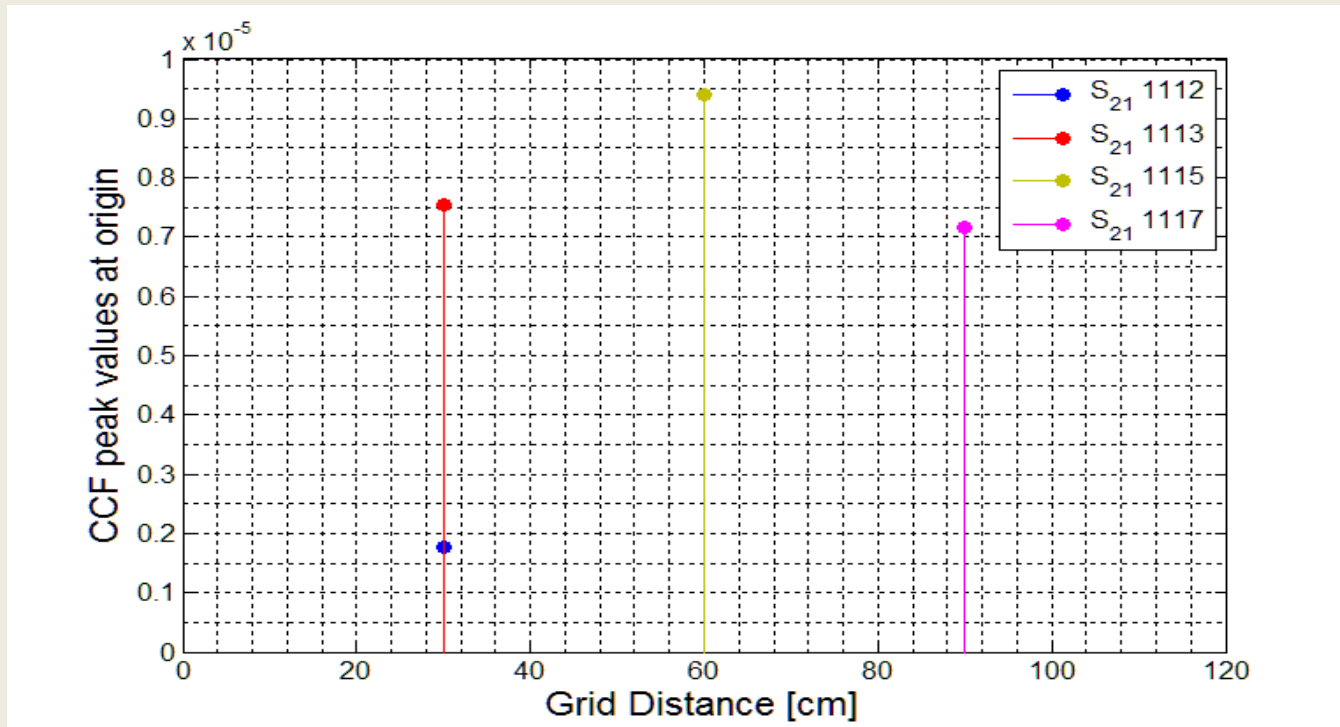
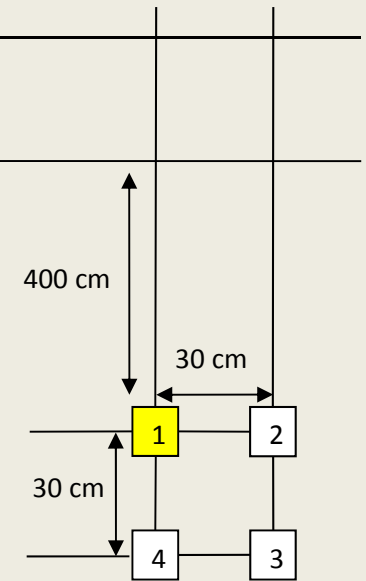
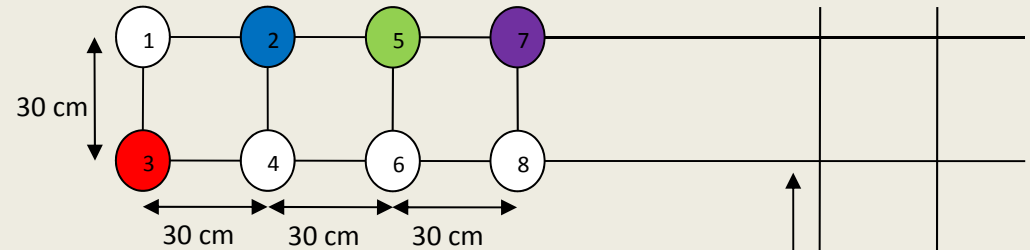

CONCLUSION



THANK YOU FOR
YOUR ATTENTION