

Magnetic Loop Antenna: Improving the Impedance Match

Klaus Solbach, DK3BA August 2022

In this article, the impedance matching of the magnetic loop antenna (MLA) is discussed using an AMA82. However, the characteristic frequency dependence of the impedance shown here occurs in all MLA projects that use magnetic coupling through a conductor loop and cover a large frequency range. Therefore, the procedure described when designing a matching circuit can also serve as a suggestion and starting point for other MLA projects.

Initial situation:

After extensive experiments with self-constructed MLAs /1,2/, a professional version, type AMA82 (by WIMO) /3/ was procured and attached to a balcony of the apartment on the second floor, see Figure 1. The antenna covers two octaves (from 3.5 MHz to 14 MHz) and, as expected, shows significantly lower losses than the home-made antenna of the same size in the same place before; this is clearly seen by the significantly smaller resonance bandwidths. On the other hand, as is also known from other magnetic loop antennas, impedance match with the help of a symmetrical coupling loop is acceptable, but still unsatisfactory: Even with optimal shaping / bending of the coupling loop, you often get the mismatch across all bands no better than below VSWR=2 to 3. This is also the case with my AMA82, which is mounted close to the house: With a NanoVNA, the reflection factor S11 of the antenna was measured directly at the feed point and results for tuning to four shortwave bands are entered in a Smith Chart (SC) in Fig.2. The coupling loop is set to slightly overcritical coupling on the lower two frequency bands, resulting in coupling becoming slightly undercritical from 10 MHz, but the VSWR remains below 1.5 up to here. However, up to 14MHz, the coupling becomes severely undercritical and the VSWR climbs to over 2.6. In the 20-meter band, when operating in transmit mode, the MLA must first be tuned to the operating frequency by adjusting the motor-driven capacitor and then the antenna must be matched using a matchbox or an automatic antenna tuner; otherwise, if the output power is set high, the transmitter reduces the transmit power due to the high VSWR. You could spare this last step if the antenna itself were much better matched; you could then even transmit over a part of the antenna bandwidth without retuning – which is good for contest situations.

So, how to match the MLA with magnetic coupling loop to low VSWR over all bands?

To solve this task, it is helpful to understand how the frequency dependency of the antenna impedance arises. For this we use the equivalent circuit diagram from /1/, see Figure 3, which clearly "models" the function of the antenna and in particular the impedance of the antenna. The required component values are obtained with the help of a circuit simulator (ADS "Advanced Design System" was used here) by looking for the component values for each frequency band that bring the calculated reflection factor as close as possible to the measured values. The component values in Figure 3 are adjusted accordingly to the measurement results in the 20-meter band.

The equivalent circuit diagram shows an R-L-C resonant circuit on the secondary side (right) of the transformer, which represents the actual radiator loop and in which the inductance of the large conductor loop is brought into resonance with the variable capacitance. With our AMA82 from Figure 1, the resistance R starts at 3.5 MHz with a few hundredths of an Ohm and rises to around 3 Ω at 14 MHz; it represents both the radiated power ("radiation resistance") and the power loss in the antenna itself ("loss resistance") and in the near field of the antenna ("ground losses"). The behaviour of the resonant circuit on the secondary side of the transformer can be shown using the circuit simulator: Figure 4 plots the calculated impedance for the case modelled in Figure 3 as a

reflection coefficient in the SC: The reflection factor runs through a circle with increasing frequency and starts at low frequencies from the left-most short-circuit point ($S_{11} = -1$), runs clockwise through the 80Ω point (slightly overcritical coupling!) with the VSWR minimum at the resonant frequency and approaches the short-circuit point again at high frequencies. This locus of the reflection factor on the primary side of the transformer describes the impedance of a parallel resonant circuit! For an antenna which is well adjusted, we find a parallel resistance of almost 50Ω for this resonant circuit and, in contrast to the strong frequency dependence of R on the secondary side, with approximately the same magnitude for all bands (explanation in /1/).

However, the measured circles in Figure 2 do not start at the short-circuit point, but at higher points on the perimeter of the SC - the necessary shift results from the impedance of the antenna with the coupling loop inductance L_3 in series connection, which has not yet been taken into account. However, not only the short-circuit point is shifted by the reactance of L_3 , but all points of the circle; the resonance point therefore moves along an inner circle of the SC (on which the real part of the impedance is constant) away from the matching point. This shift is shown in Figure 4: The inductance of the coupling loop of around $1 \mu\text{H}$ results in a reactance of around 72Ω or 1.4 times the characteristic impedance. The apparent origin of the shifted resonance curve is therefore at point 1.4 on the perimeter of the SC. The circle becomes significantly smaller as a result of the shift, so that the resonance point shows a VSWR of around 3.5, and slightly above the resonance frequency the best match is achieved with a VSWR of around 2.6. The important finding is that the resonance curve shifts further the higher the frequency, so that the worst match of our MLA is found in the highest frequency band, i.e., in the 20-meter band for the AMA82.

What options are there for improving the impedance match?

In order to reduce the inductance of the coupling loop, it is unfortunately not possible to arbitrarily reduce the size of the coupling loop, since the transformer turns ratio required for the adjustment is essentially determined by the ratio of the sizes of the large loop and the coupling loop. However, the inductance of the coupling loop can be minimized by designing the coupling loop with the largest possible diameter of the coaxial inner conductor - in our case, a flexible coaxial cable with an outer diameter of 10 mm is used, with the outer conductor serving as symmetrical shielding. There is little potential for improvement here by using a cable with a slightly larger diameter. Without the insertion of an additional matching circuit, there would then only remain to seek a better compromise between matching of the lower and matching of the upper bands by appropriate shaping of the coupling loop /4/; in experimental projects also by increasing or reducing the length (circumference) of the coupling loop, but only within narrow limits, see above. These are the means that are often discussed in the literature and in many internet contributions - and in so far this is "state of the art".

A decisive improvement is possible only using an extra matching circuit. In the simplest case, a capacitor connected in series would work: This would compensate for the inductive reactance of the coupling loop and the resonance curve would be "turned back". But alas: A capacitor that turns enough at 14 MHz will turn a lot more at 3.5 MHz, since the capacitive reactance is 4 times larger - and this only shifts the mismatch to the lower bands but is no solution of the problem.

So, you need an adjustment element that has the greatest effect at the upper frequencies and the smallest effect at the lower frequencies: In principle, this is exactly what an inductance in a series circuit does, whose reactance also decreases with decreasing frequency! However, the inductance cannot be connected directly, because then the problem would only be increased. The trick is to first apply a transmission line transformation that rotates the resonance circle of the 20-meter band to the lower, the capacitive half of the SC. Only then does a series-connected inductance shift the impedance of the antenna towards the centre of the SC, where we find impedance match: The circuit

can be seen in Figure 5 and Figure 6 shows this transformation in the two steps. The transmission line transformer consists of a 2.13 m long coaxial line (RG58), which shifts the resonance circle in the SC clockwise by about 110° at 14 MHz. The inductance then shifts all points of the resonance circle clockwise again along circles (constant real part of the impedance) upwards towards the centre of the SC.

The angular displacement by the transmission line is also strongest at the highest frequency, so that the resonance circle of the 30-meter band is only just rotated to the open-circuit point of the SC on the far right ($S_{11} = +1$). There, the series connection with the inductance L_4 only leads to shifts from points on the resonance circle to other points on the same circle, which does not result in any improvement in the matching. The resonance circles of the lower frequency bands are correspondingly rotated even less and remain in the upper half of the SC. Together with the decreasing shift caused by the series-connected inductance, there is a pleasing "resorting" of the resonance curves as shown in Figure 7: All resonance curves are now more or less shifted, but except for the 30-meter band they are significantly closer to perfect match. The picture does not change when the resonant frequency of the antenna is tuned across the bands, i.e., the matching circuit has a broadband effect.

The implementation of the transformation circuit in a box below the feed point of the AMA82 can be seen in Figure 8. The length of the transformation transmission line is the total length of the coax cable from the plug on the antenna feed point connection socket down to the inductance. The larger part of the cable is wound up in the box and the inductance is realized with about 5 windings on an iron powder toroidal core.

References

/1/ Klaus Solbach, "Magnetic Loop Antenna: Calculation, simulation, equivalent circuit diagram, measurement and improved understanding of operation", 2022, https://www.uni-due.de/hft/amateurfunk_en.php

/2/ Klaus Solbach, "Magnetic Loop Antenna: Five misconceptions", 2022, https://www.uni-due.de/hft/amateurfunk_en.php

/3/ <https://www.wimo.com/de/ama-82>

/4/ Installation and operating instructions for the AMA, from WIMO Antennen und Elektronik GmbH, 2022



Fig.1 The AMA82 on the author's balcony.

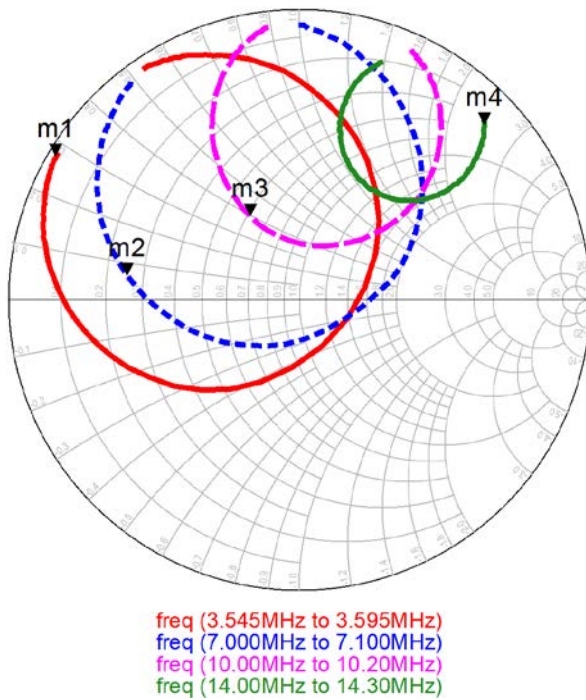

Fig.2 The measured reflection factor S_{11} of the AMA82 in four shortwave sub-bands from 3.5 MHz to 14 MHz. The bandwidths of the sub-bands shown increase with frequency because the resonance

bandwidths also increase (the resonance bandwidth in the 80-meter band is around 4 kHz at VSWR=2.6).

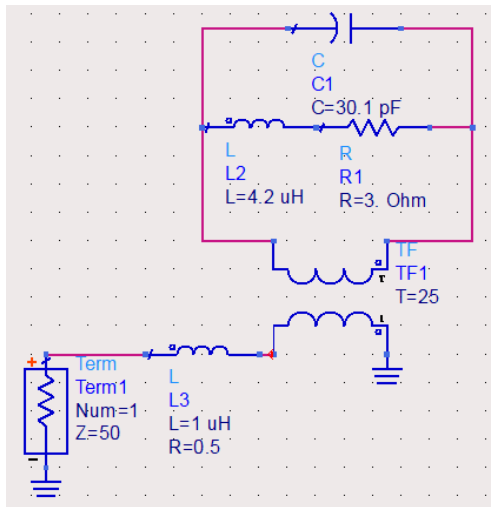

Fig.3 The equivalent circuit diagram of my AMA82 in the 20-meter band.

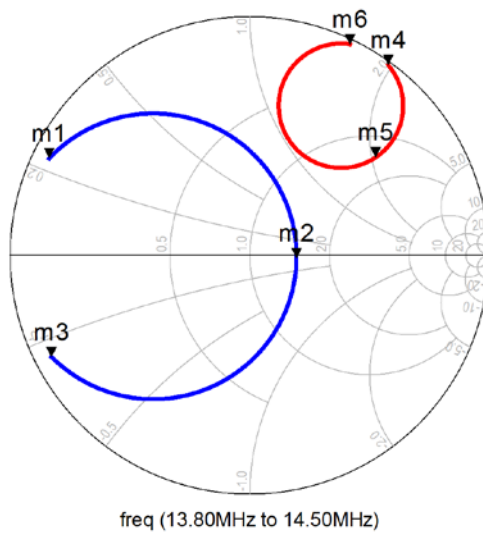

Fig.4 The impedance of the circuit in Figure 3 is plotted as S11 in the SC for the 20-meter band. On the left without inductance L3 and on the right the full impedance with the reactance of inductance L3 (about 1.8·50 Ω). Low frequency at markers m1 and m4, resonance frequency at markers m2 and m5, high frequency at markers m3 and m6. Best match with VSWR = 2.6 just above the frequency of marker m5.

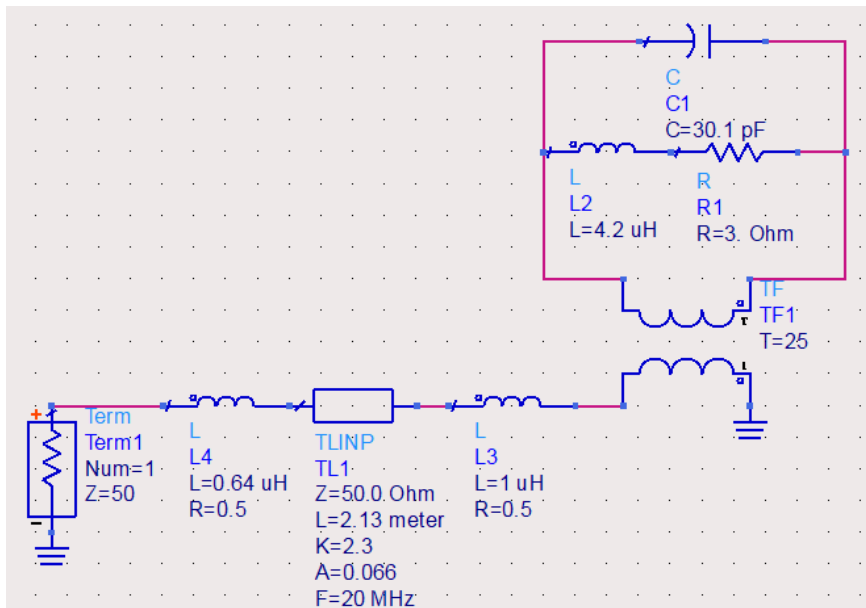

Fig.5 Equivalent circuit diagram of the AMA82 with added matching circuit made of coaxial line TL1 and inductance L4.

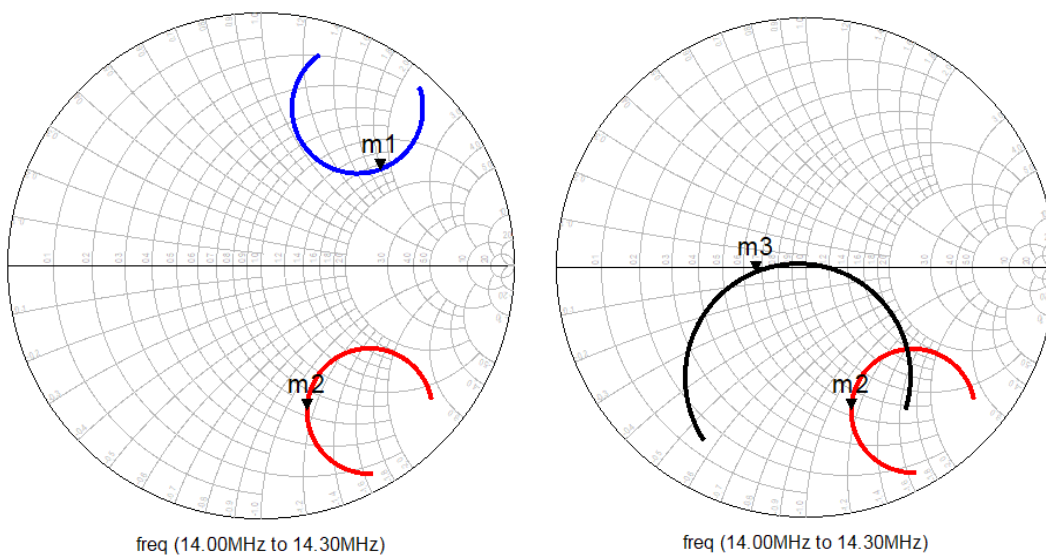
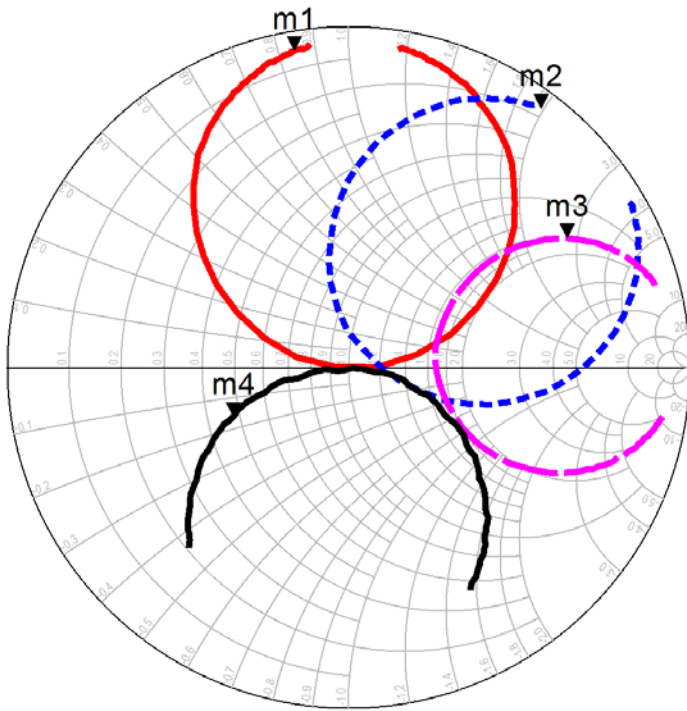

Fig.6 The impedance transformation in two stages. Left: Line TL1 moves marker m1 to m2. Right: The subsequent inductance L4 shifts marker m2 to m3.



freq (3.545MHz to 3.595MHz)
 freq (7.000MHz to 7.100MHz)
 freq (10.00MHz to 10.20MHz)
 freq (14.00MHz to 14.30MHz)

Fig.7 The measured reflection factor of the AMA82 with transformation circuit in the four shortwave bands.



Fig.8 The realized matching circuit seen in a plastic box (open) mounted to the mast just below the feed point of the AMA82.